



SUPER TWEETER TW350-Ti



The PRV Audio TW350-Ti Super Tweeter offers a smooth response and extremely high efficiency from mid range through high range frequencies.

The Titanium diaphragm is less harsh than some metal based diaphragms and is on a Kapton former is light, thin and durable for long play applications.

The TW350Ti is perfect for DJ Cabinets, and can may be for higher SPL Requiements. The sharp smooth sound is perfect for applications where larger compression drivers may over power a venue.

The magnet assembly is designed to concentrate energy at the voice coil gap and is assembled with durable ABS.

TW350-Ti is designed to ensure a quality sound and long lasting play in most any environment. Replacement Diaphragms available.

TECHNICAL SPECIFICATIONS:

Nominal Impedance.....	8	Ω
RMS Power.....	60	Wrms
Musical Program Power ¹	120	W
Sensitivity ²	105	dB_SPL
Frequency Response @ -10db(Hz).....	3-25	kHz
Min Recommended Crossover Point.....	5000	Hz
Voice Coil Diameter.....	1	in
RE (Voice Coil Resistance).....	7.8	Ω
Voice Coil Material.....	Copper	
Voice Coil Former Material.....	Kapton Titanium	
Gross Weight.....	1.32	Lbs

¹ With Crossover at 5000Hz, 12db octave

² Average between 1.2kHz & 15kHz (2.83v@1m)

NOTE: Driver must be connected to a crossover that meets recommended specifications.

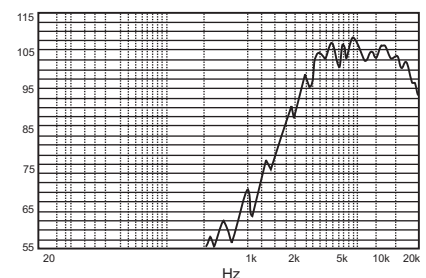
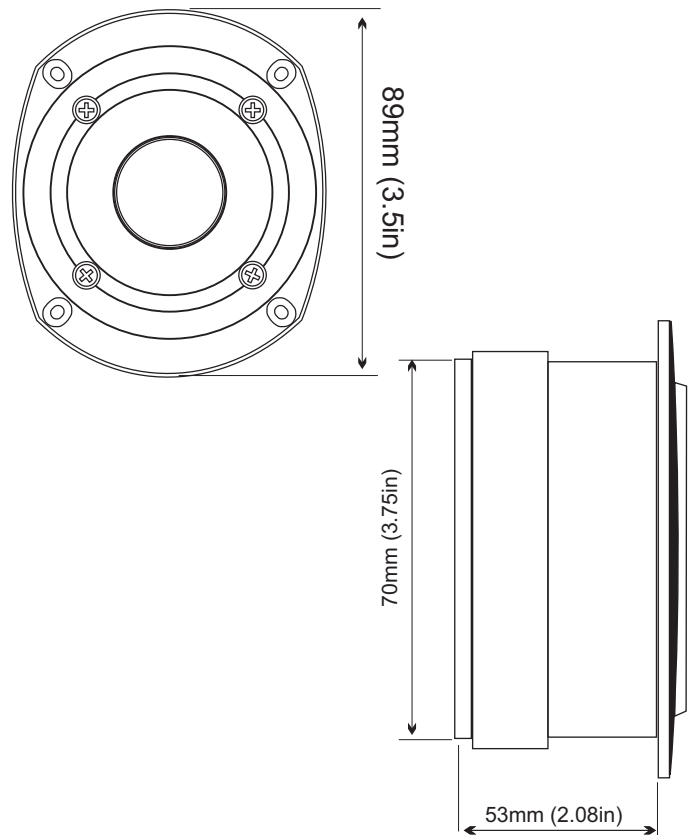

PRV AUDIO USA (all USA and export sales)
2000 N.W. 95th Ave
Miami, FL 33172- USA
support@prvaudio.com
http://www.prvaudio.com

PRV AUDIO BRAZIL (only brazilian sales)
SAO LEOPOLDO, RS
+55 51 3566-2626
vendas@pvaudio.com.br
http://pvaudio.com.br