



COMPRESSION DRIVER D260Ti



The PRV Audio D260Ti Compression Driver is light weight and offers unsurpassed vocal and mid range reproduction.

A specially designed and easily replaceable Titanium diaphragm on a Kapton former is light, thin and durable for long play applications and offers a smooth natural sound required for proper voice production systems.

The D260Ti is perfect for stage monitors, studio monitors, and stage speaker enclosures where a high sound quality is required, and weighs just 2 lbs.

The magnet assembly is designed to concentrate energy at the voice coil gap and is assembled with a standard 1 3/8" screw for easy replacement with current 1" horns or it can be used as a bolt on horn offering you more diversity.

D260Ti is designed to ensure a quality sound and long lasting play in most any environment.

TECHNICAL SPECIFICATIONS:

Nominal Impedance.....	8	Ω
RMS Power ¹	60	Wrms
Sensitivity ²	106	dB_SPL
Frequency Response @ -10db(Hz).....	1,000-20k	Hz
Recommended Crossover Point.....	2,000	Hz
Exit Diameter.....	1	in
Voice Coil Diameter.....	1.4	in
RE (Voice Coil Resistance).....	6.4	Ω
Voice Coil Material.....	Copper	
Voice Coil Former Material.....	Kapton	
	Titanium	
Magnet Material.....	Ferrite	Lbs
Net Weight.....	.95/2.09	kg/lbs
Mounting Depth.....	65/2.56	mm/in
Overall Diameter.....	90/3.54	mm/in

¹ With Crossover at 2kHz, 12db octave

² Average between 1.2kHz & 15kHz (2.83v@1m)

NOTE: Driver must be connected to a crossover that meets recommended specifications.

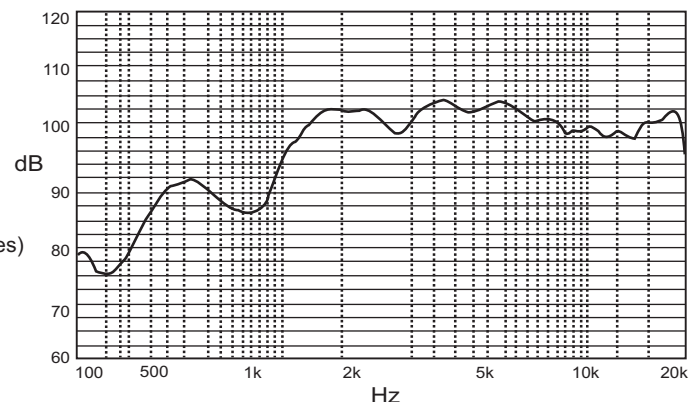
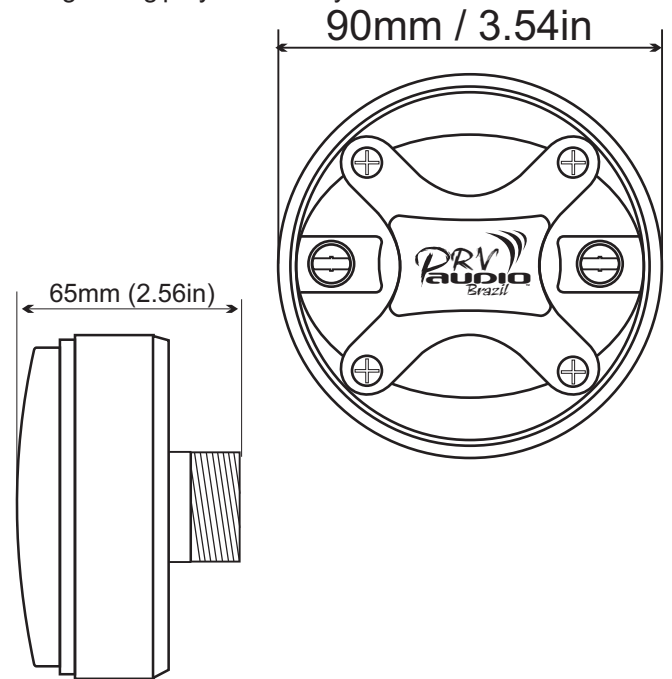

PRV AUDIO USA (all USA and export sales) PRV AUDIO BRAZIL (only brazilian sales)
 2000 N.W. 95th Ave
 Miami, FL 33172- USA
 support@prvaudio.com
 http://www.prvaudio.com

SAO LEOPOLDO, RS
 +55 51 3566-2626
 vendas@pvaudio.com.br
 http://pvaudio.com.br